

C170 Food Grade

Continuous Inkjet Printing System.
High Speed. Non-contact.
Print Direct to Food Products.
USDA/FDA approved
and compliant inks.



Simplified, extended operation, lower cost of ownership. Print direct to food products.

The C170 Food Grade is targeted at printing direct to food products such as eggs, baked products and many products for human and animal consumption. USDA and FDA compliant inks are available in red, blue and green colors. Print up to 5 lines of text or graphics.

The C170 Food Grade can manage with ease one, two or three shifts per day or 24/7 operations, five to seven days per week, averaging 4,000 - 8,760 hour annual operation.

High speed processing and CIJ electronic hardware design ensure millions of draw patterns are dynamically adjusted on the fly, maximize print quality and speed.

Utilize integrated RS232 and programmable inputs/outputs for remote control and communications.

Systems are simplified to allow anyone to operate, minimizing operator touches and extending time between human interaction.

- **CleanStart™** : automatically cleans printhead eliminating daily and weekly cleanings.
- **10.4" Color Touch Screen** : always on, vivid display with large intuitive buttons and status indicators.
- **OneTouch™** : single step operator functions reduce operator steps.
- **Large Volume Ink Tanks** : extend time between fluid additions to weeks or months.
- **On-the-Fly External Ink Filling** : accomplished in less than a minute with no waste.
- **AutoOff™ Go Home Button** : automate and eliminate time consuming end of day manual routines.





Industrial, designed to the extremes.

- **BUILT TO LAST FOR THE HARSHTEST PRINTING APPLICATIONS**

Printheads are industrial stainless steel, built-to-last for the harshest printing applications.

- **FASTEST PRINT SPEEDS FOR ANY APPLICATION**

Up to 1500 feet/minute (470 meters/minute) for single line of print,
Up to 345 feet/minute (108 meters/minute) for two lines of print,
Up to 173 feet/minute (54 meters/minute) for three lines of print,
Up to 119 feet/minute (36 meters/minute) for four lines of print,
Up to 114 feet/minute (35 meters/minute) for five lines of print .

Mark and code everything. Print on anything

- **LINES OF PRINT**

1, 2, 3, 4 or 5 lines of text, graphics and barcodes.

- **IMAGE HEIGHT**

From 0.06" (1.5 mm) to 0.75" (19 mm).

- **TRUE NON CONTACT PRINTING**

Ink throw distances from 0.5" (12 mm) up to 2" (50 mm).



C170 Food Grade Specifications

Technology - Continuous Ink Jet (CIJ) Technology, Single Printhead Control

User Interface - 10.4" (264 mm) Color LCD, Touch Screen, Icon based – Graphical User Interface (GUI)

Lines of Print - 1 - 5 Lines, 32 Pixel

Print Fonts - 5, 7, 9, 12, 16, 19, 25, 32

Adjustable Print Height - 0.06" (1.5 mm) - 0.50" (12 mm)

Optional Print Height - 0.10" (2 mm) - 0.75" (19 mm)

Print Speed -

1 Line: 1500 feet/minute (470 meters/minute),

2 Line: 345 feet/minute (108 meters/minute),

3 Line: 173 feet/minute (54 meters/minute),

4 Line: 119 feet/minute (36 meters/minute),

5 Line: 114 feet/minute (35 meters/minute)

Ink Throw Distance - True Non-Contact Printing, 0.5" (12 mm) - 2" (50 mm)

Electronic Hardware - 32 Bit ARM 9, 208 Mhz Processor

Memory Storage - 4 GByte Solid State Drive, 15 MByte Flash, 128 Mbyte RAM, USB Interface (thumb drive)

Machine Interface - RS232, Ethernet

Inputs - 1 Photocell, 1 Photocell or Programmable Input, 1 Shaft Encoder, 8 Field Programmable Inputs, Remote Message Selection option – 256 possible selections

Outputs - 4 Alarm Outputs, 1 Relay Output

Enclosure - Stainless Steel Enclosure

Ingress Protection - IP65

SmartFilter™ Life - 2,000 hours

Operating Environment - Temperature: 32° - 122° F (0° - 50°C), % Relative Humidity: 10 - 90% (non-condensing)

Electrical Requirement - Auto Ranging: 100 - 240 VAC (3 Amp), Frequency 50 - 60 Hz, Power Consumption: 50 W

Compliance - CE Certified, RoHS Compliant

Message/Code Creation -

Dynamic Message Storage (over 1000 Messages), WYSIWYG Message Editing, Drag/Drop Field Based Formatting, Multi-National (Unicode) Character Printing, Download Fonts, Integrated Font Editor, Real and Expiration Time and, Date, Shift and Rollover Functions, Product and Batch Counting, Remote Count Resets, Download Graphics and Integrated Graphic Editor, Continuous and Repeat Print, Auto Reverse/Traverse Print

Operation Features - Icon Based Operation, Single Button Start, Single Button Stop/Power Off, Password Security, Automatic Diagnostics, Error and Activity Logs, Service Reminders, Backup/Restore Functions, USB, Load Firmware Updates, All Operator Languages, Download Languages

Ink Delivery - SmartFill™ Ink Bottle: 32 oz (946 ml), SmartFill™ Makeup Bottle: 32 oz (946 ml)

Fluid Capacity - Ink Capacity: 68 oz (2 liters), Makeup Capacity: 102 oz (3 liters)

Ink Types - Print Direct to Food Products - Food Grade USDA, FDA Approved and Compliant

Ink Colors - Red, Blue and Green

Ink Dry Time - Porous Food: immediate. Semi-porous food: immediate. Non-porous: 3 to 7 seconds

Printhead Umbilical - 10 feet (3 meters), 15 feet (4.5 meters) option

Printhead Options - Right Angle Printhead

Printing - Printhead Orientation – Omnidirectional

Weight - 45 lbs (20 kg)

Optional Accessories - Alarm Beacon, Photocells, Mountings, Shaft Encoder, AirFlow™ Positive Air Kit (for high dust), Printhead Wash Station

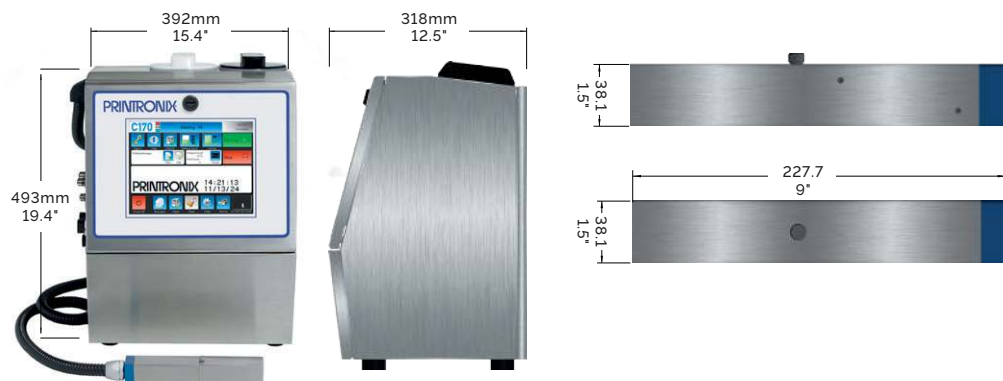

Printronix LLC
7700 Irvine Center Dr,
Suite 700, Irvine,
CA 92618, United States
www.primtronix.com

PRINTRONIX